

1 TYPICAL CORNER  
1:2 @ A4

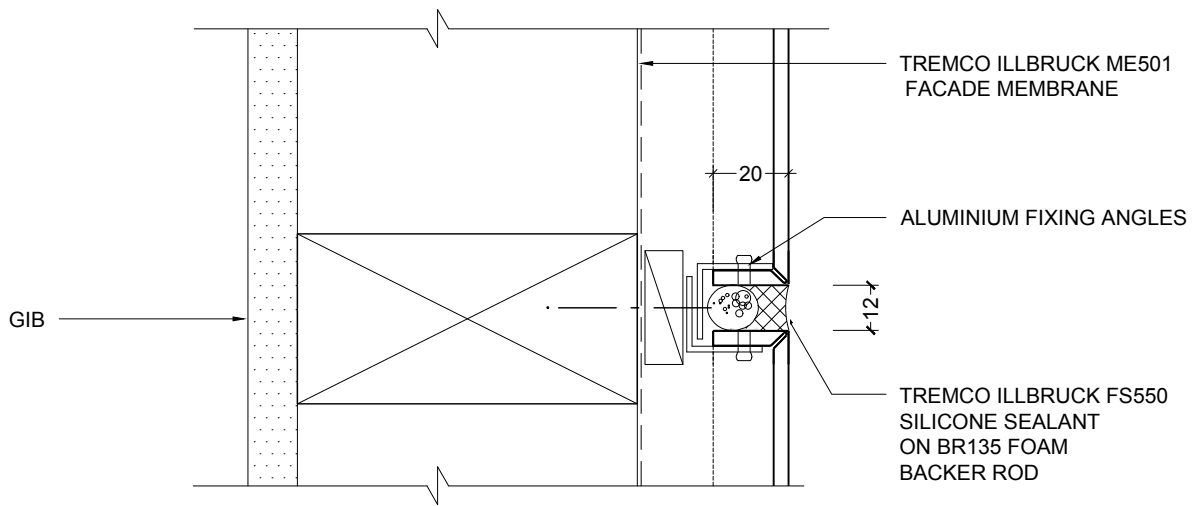

2 TYPICAL VERTICAL JOINT  
1:2 @ A4

NOTE: FRAMING TO BE AT 600 CTRS MAX FOR BOTH STUDS AND NOGS. MAY BE REQUIRED AT CLOSER CENTRES SUBJECT TO ENGINEERING REQUIREMENTS.

FRASER GLOBAL TRADING (PTY) LTD

JHB: (011) 450 0263  
DBN: (031) 564 8692  
Email: info@fgtrading.co.za  
Website: www.fgtrading.co.za



Project:  
Alcopanel Details

Drawn by: LS

Scale: 1:2

Date: 23/03/2015

Drawing No.  
FG/AP03