

GMS SL Series Glass Carriers

September 2015

Glass Handling Equipment

Description

The SL Series Glass Carriers are designed to aid a glazier in unloading, transportation and installation of large sheets of glass as well as lifting glass into place.

A single operator is able to offload a glass panel of 150kg from a rack, rotate the glass to the horizontal and then lower it precisely onto a worktable.

The device is able to pass through a narrow 700mm wide doorway and its 10" solid puncture-proof wheels allow travelling over rough ground on construction sites.

Key Features & Benefits

- Patented, stylish and easy to operate even when lifting 150kg. Automatically locks load at any height.
- Foldable design for easy transportation in vans and trucks or storage on shelves and benches
- Steel wire is hidden within mast preventing finger pinching

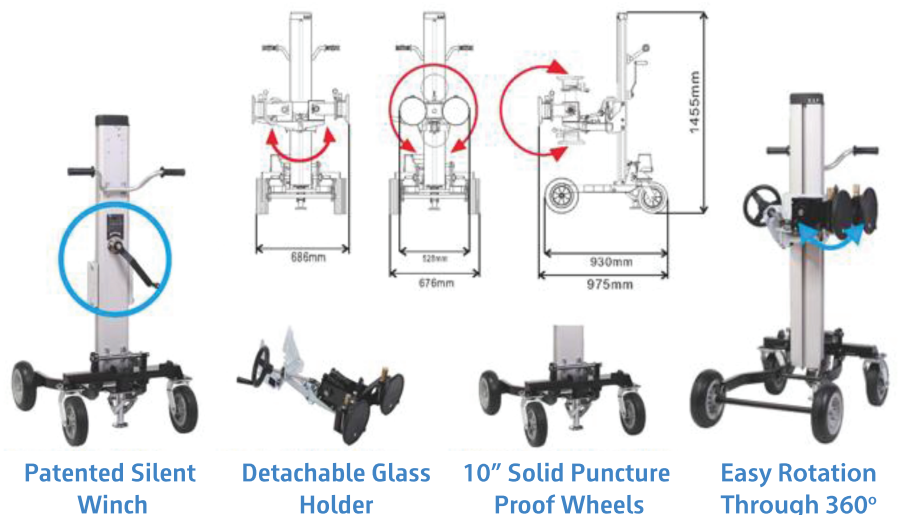

Patented Silent Winch

Detachable Glass Holder

10" Solid Puncture Proof Wheels

Easy Rotation Through 360°

Technical Data

Model	SL1	SL2
Lifting height	1050mm	1050mm
Max load capacity	70kg	150kg
Dimensions	980mm x 700mm x 1460mm	980mm x 700mm x 1660mm
Mast weight	17kg	19kg
Base weight	15kg	19kg
Holder weight	19kg	23kg

Fraser Global Trading Pty Ltd

Website: www.fgtrading.co.za

Information: info@fgtrading.co.za

Orders: sales@fgtrading.co.za

JHB Tel: 011 450 0263

Fax: 011 450 0306

DBN Tel: 031 564 8692

Fax: 031 564 8691